

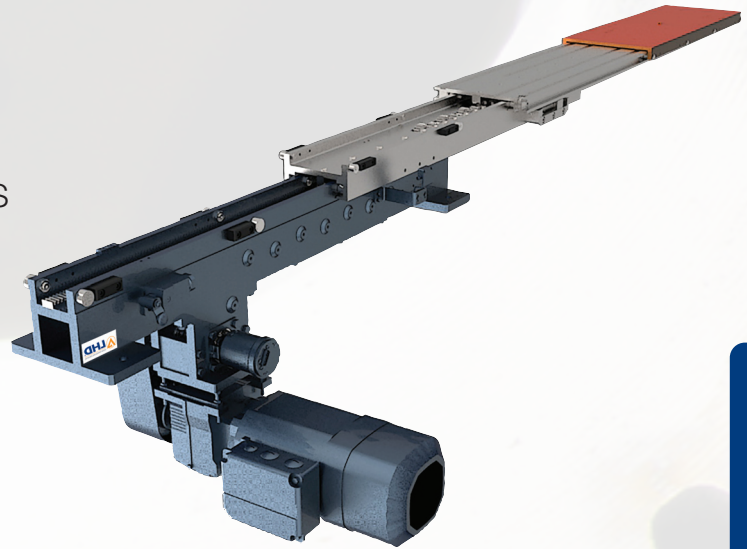

ZEUS 85

With 10 mm more thickness than the ZEUS 75, the ZEUS 85 is particularly fit for those applications with a small required space of the slides. The fixed body consists of parts made of a steel/aluminium compound; hence, the total weight of the device is limited.



SINGLE DEPTH

DOUBLE DEPTH

PRODUCT CODE	Q LOAD (KG)	L FIXED BODY LENGTH (MM)	LS UPPER SLIDE LENGTH (MM)	S2 STROKE (MM)	MAX BENDING UNDER LOAD (MM)
Z85-070	120	700	700	1400	13
Z85-080		800	800	1600	18
Z85-090	100	900	900	1750	19
Z85-100		1000		1950	27
Z85-110	75	1100	1000	2150	28
Z85-120	50	1200		2400	30

The ZEUS 85 is recommended as single fork with a larger plate installed on top, for handling small carton or plastic boxes within the miniload sector.

TRIPLE DEPTH

COMBINED PRODUCTS

SPECIAL PRODUCTS

