

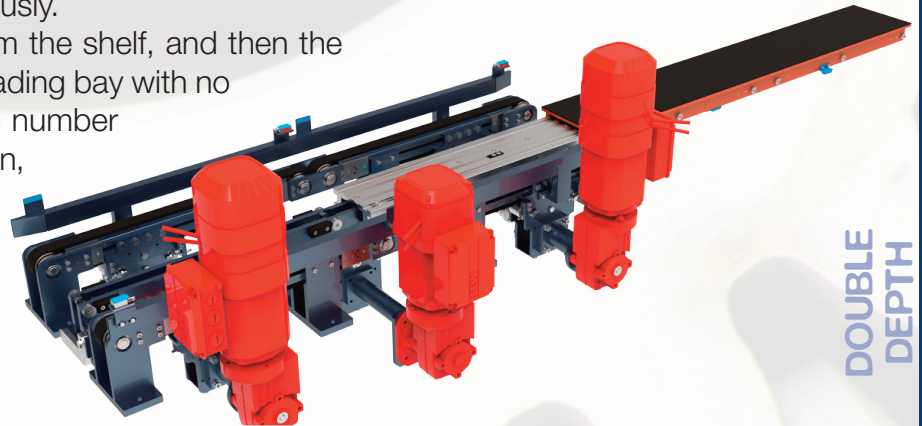

# PHOEBUS X1/X2 BELT CONVEYORS

Designed for backing up the telescopic forks, the lateral belt conveyor allows moving the loads onboard simultaneously.

The fork set can pick up the load from the shelf, and then the PHOEBUS can lay it down in the unloading bay with no further need of telescopic stroke; the number of belts can be redoubled in the X2 version, thus making it even more flexible and versatile - it can also handle a double load onboard.



SINGLE  
DEPTH

DOUBLE  
DEPTH

TRIPLE  
DEPTH

Q1	LOAD VERSION X1 (KG)	Q2	LOAD VERSION X2 (KG)	L1	LENGTH VERSION X1 (MM)	L2	LENGTH VERSION X2 (MM)	DB	DISTANCE BETWEEN BELTS (MM)
50	100			420	650			300	
				620	800				
				820	950			350	
				1050	1100			400	
				1250	1250			500	

Therefore, it's possible to halve the operation time by handling two loads at once. The same system can involve chains instead of belts, to handle way bigger loads with the same benefits.

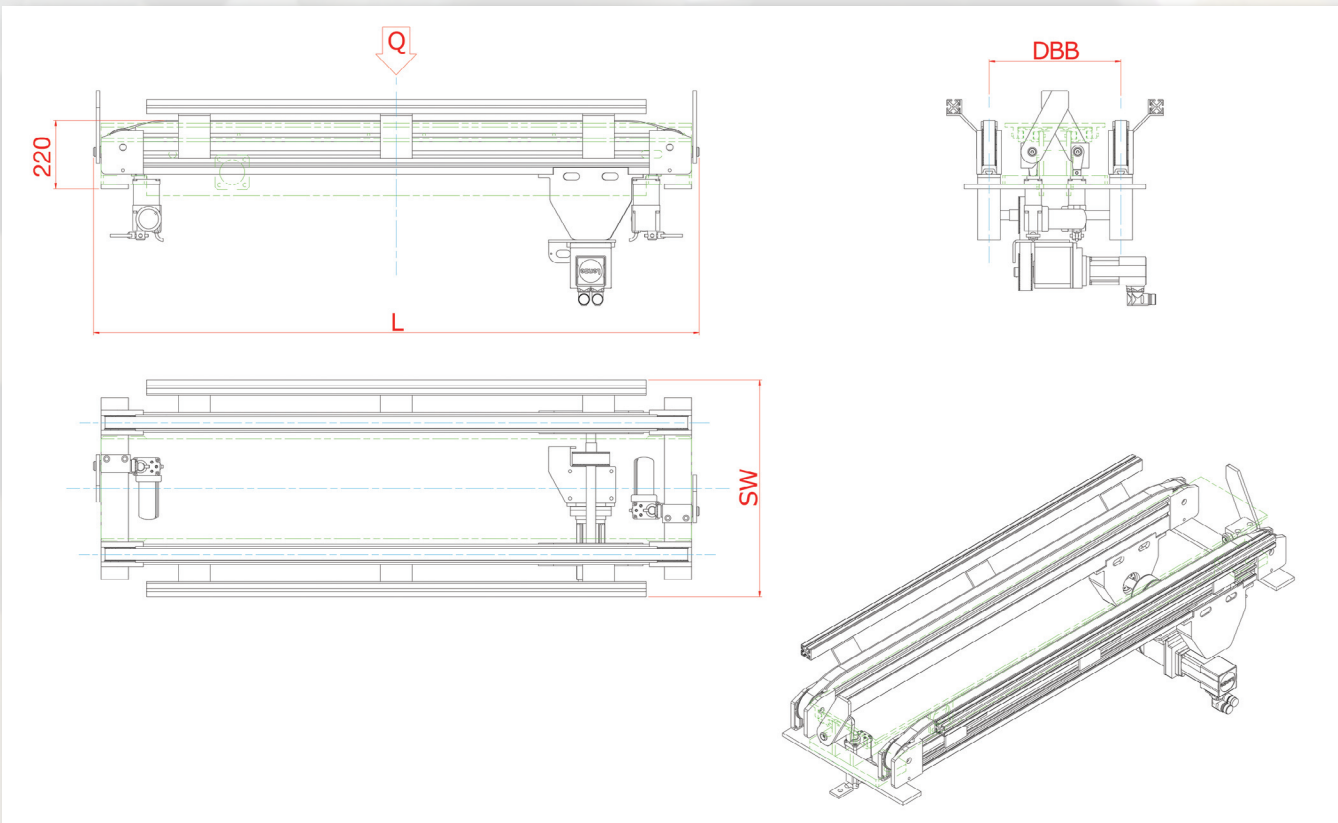

COMBINED  
PRODUCTS

SPECIAL  
PRODUCTS