



CERBERUS X1

3-SIDED SYSTEM

The CERBERUS with fixed forks allows handling pallets with only 42 mm fork thickness and a load capacity up to 1500 Kg. Rotation and translation occur at a speed of 30m/min.

Thanks to this system, the pallets can be set down and picked up even rotated by 90° compared to the normal position in warehouses.

The device is operated through a pinions-and-racks transmission. The whole structure is supported by a system of prismatic rails, their size depending on the weight the equipment is designed for.

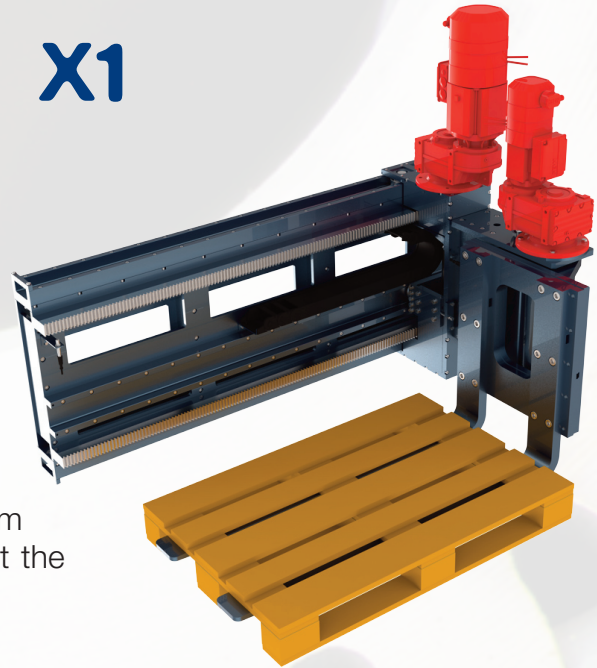

SINGLE
DEPTH

DOUBLE
DEPTH

PRODUCT CODE	Q LOAD (KG)	SL SYSTEM LENGTH (MM)	S STROKE (MM)	FL FORKS LENGTH (MM)	DBF DISTANCE BETWEEN FORKS (MM)	TH SYSTEM HEIGHT (MM)
CX1-170	1500	1700	1350	1200	370 to 600	1500
CX1-180		1800	1450			
CX1-190		1900	1550			
CX1-200		2000	1650			

A motor placed on top operates the spinning movement. Both movements of rotation and translation can occur at the same time in masked time.

TRIPLE
DEPTH

COMBINED
PRODUCTS

SPECIAL
PRODUCTS

