



ATHENA 220

This equipment is made of special materials and innovative solutions have been employed for its development. It's mainly used in the paper industry to handle big paper coils, or in precision, industries to automatically feed e.g. laser cutting or bending machines, or to handle chipboards and the like.



SINGLE DEPTH

PRODUCT CODE	Q LOAD (KG)	L FIXED BODY LENGTH (MM)	LS UPPER SLIDE LENGTH (MM)	S1 STROKE (MM)	MAX BENDING UNDER LOAD (MM)
AT220-130	4000	1300	1300	1400	2
AT220-150		1500	1500	1600	
AT220-170		1700	1700	1800	3
AT220-190		1900	1900	2000	
AT220-220		2200	2200	2300	4
AT220-250		2500	2500	2600	6
AT220-290		2900	2900	3000	8

Notably low bending and long life cycle are its strong points. This equipment is the ultimate solution for purposes other forks are not fit for, offering remarkable performances for speed and acceleration. It's only available with the pinions and racks system.

DOUBLE DEPTH

TRIPLE DEPTH

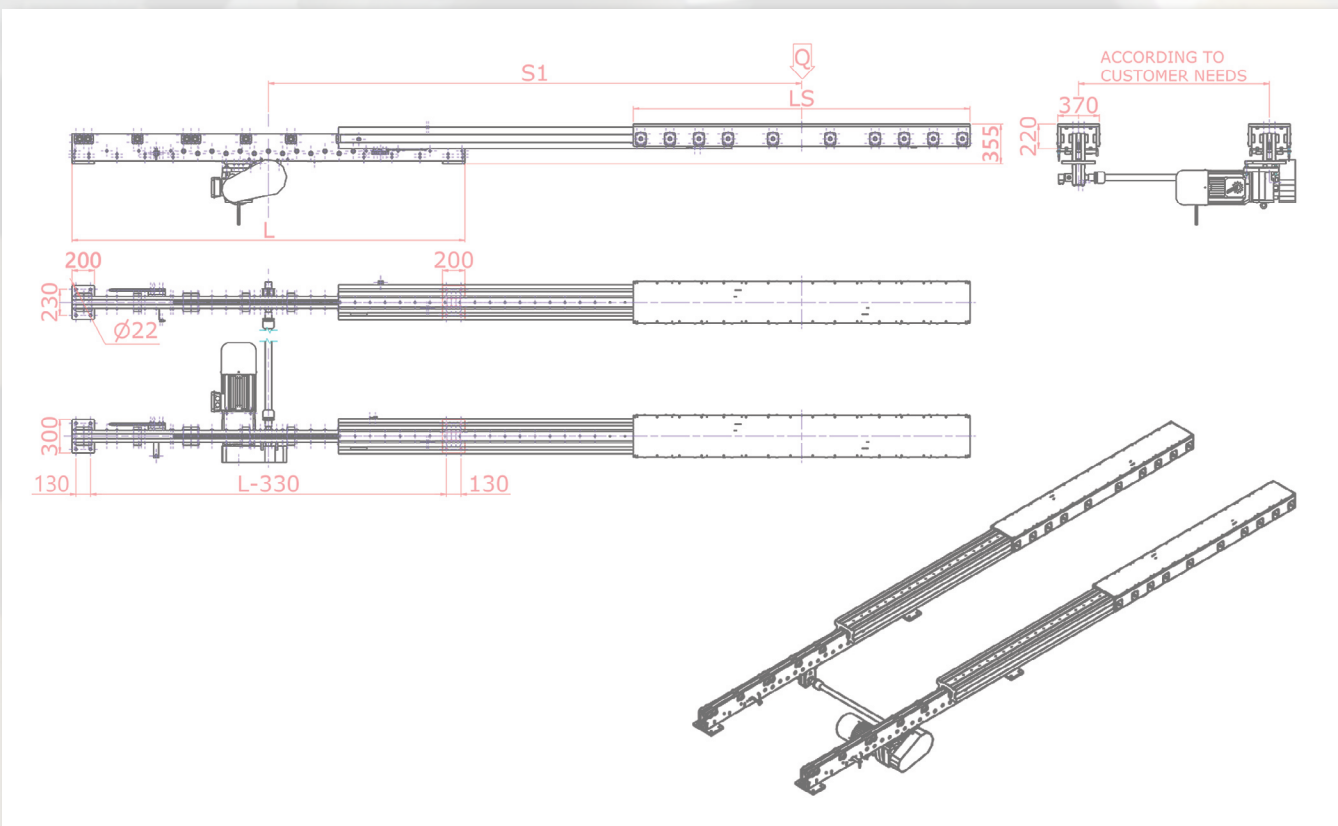

COMBINED PRODUCTS

SPECIAL PRODUCTS