

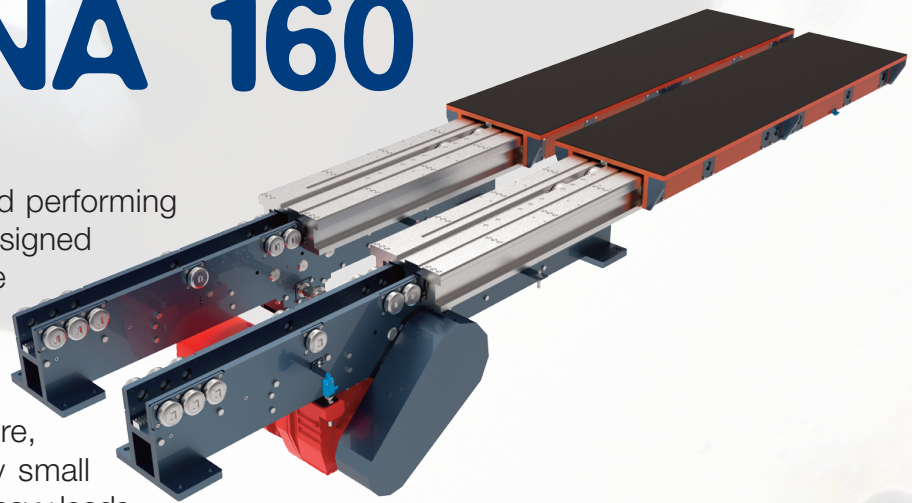

ATHENA 160

It's a very strong, tough and performing telescopic fork, expressly designed by LHD to fill a gap in the choice of telescopic forks in order to fulfil the needs of current handling industry.

Thanks to its tough structure, the ATHENA 160 has a very small bending, even when carrying heavy loads.



SINGLE DEPTH

DOUBLE DEPTH

TRIPLE DEPTH

COMBINED PRODUCTS

SPECIAL PRODUCTS

PRODUCT CODE	Q LOAD (KG)	L FIXED BODY LENGTH (MM)	LS UPPER SLIDE LENGTH (MM)	S1 STROKE (MM)	MAX BENDING UNDER LOAD (MM)
AT160-130	5000	1300	1300	1400	5
AT160-150		1500	1500	1600	6
AT160-170		1700	1700	1800	8
AT160-190		1900	1900	2000	10
AT160-220		2200	2200	2300	13
AT160-250		2500	2500	2600	15
AT160-290		2900	2900	3000	22

Mostly suitable for handling coils within paper and steel industries, it's also very suitable for handling car bodies and chassis within the automotive sector.

The ATHENA 160 is an excellent intermediate solution to have a powerful, safe and competitive equipment, repeatability being its strong point.

