

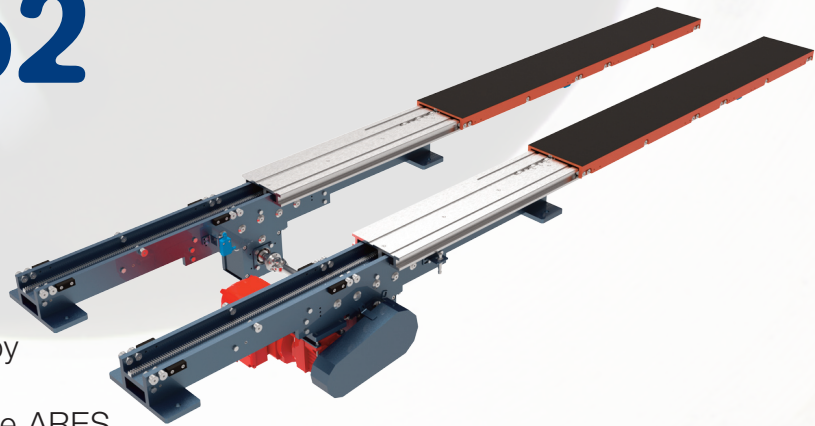

ARES 52

The ARES 52 is a fork designed for handling medium-light loads; it displays similar features to the ARES 40, the only difference being the transmission system runned by hardened gears and racks.

This kind of transmission allows the ARES 52 to operate at outstanding speeds and acceleration, with extraordinary work paces. Its strong points are repeatability and precision.



PRODUCT CODE	Q LOAD (KG)	L FIXED BODY LENGTH (M/M)	LS UPPER SLIDE LENGTH (M/M)	S1 STROKE (M/M)	MAX BENDING UNDER LOAD (M/M)
AR52-065	200	650	650	750	4
AR52-070		700	700	800	5
AR52-080		800	800	900	6
AR52-100		1000	1000	1100	8
AR52-120		1200	1200	1300	11
AR52-125		1250	1250	1350	12
AR52-145		1450	1450	1550	17

Because of the high performances, it's recommended to take into account the stability of the load. Also the ARES 52 is suitable to be used as single fork.

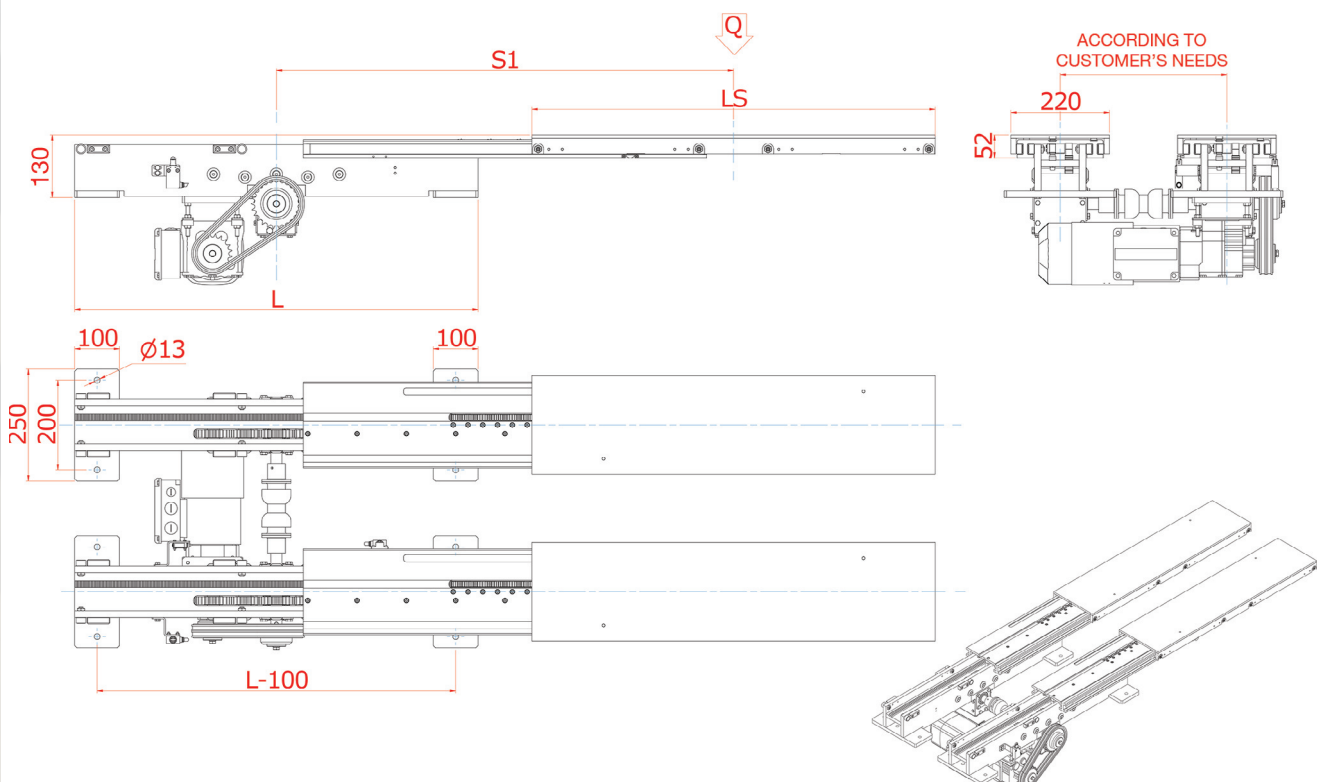

SINGLE DEPTH

DOUBLE DEPTH

TRIPLE DEPTH

COMBINED PRODUCTS

SPECIAL PRODUCTS