

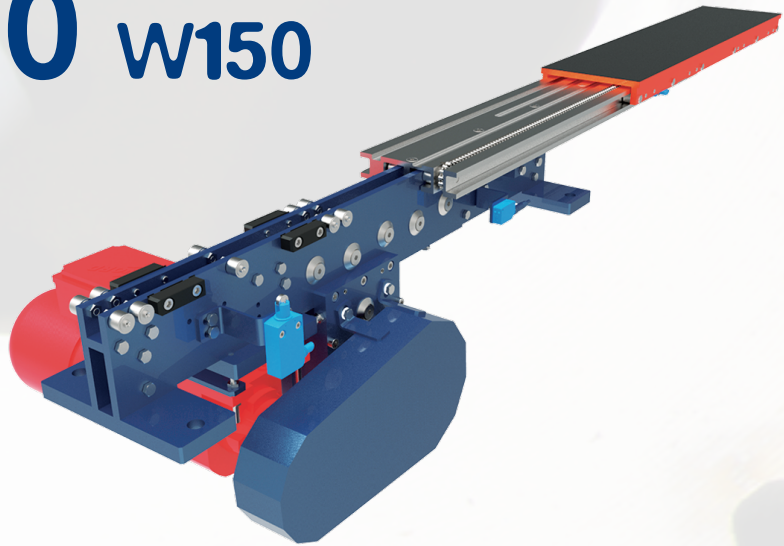

ARES 40 W150

The ARES 40 W150 fork is designed to handle loads with limited weight, especially where a good size/load ratio is required.



SINGLE DEPTH

DOUBLE DEPTH

TRIPLE DEPTH

COMBINED PRODUCTS

SPECIAL PRODUCTS

PRODUCT CODE	Q LOAD (KG)	L FIXED BODY LENGTH (MM)	Ls UPPER SLIDE LENGTH (MM)	S1 STROKE (MM)	MAX BENDING UNDER LOAD (MM)
AR40W5-065	100	650	650	750	5
AR40W5-070		700	700	800	6
AR40W5-080		800	800	900	7
AR40W5-100		1000	1000	1100	12
AR40W5-120	70	1200	1200	1300	14
AR40W5-125		1250	1250	1350	16
AR40W5-135	50	1350	1350	1450	24

Chains and pulleys provide the movement of the top element. This light series of telescopic fork achieves remarkable performances as for top speed and acceleration.

