

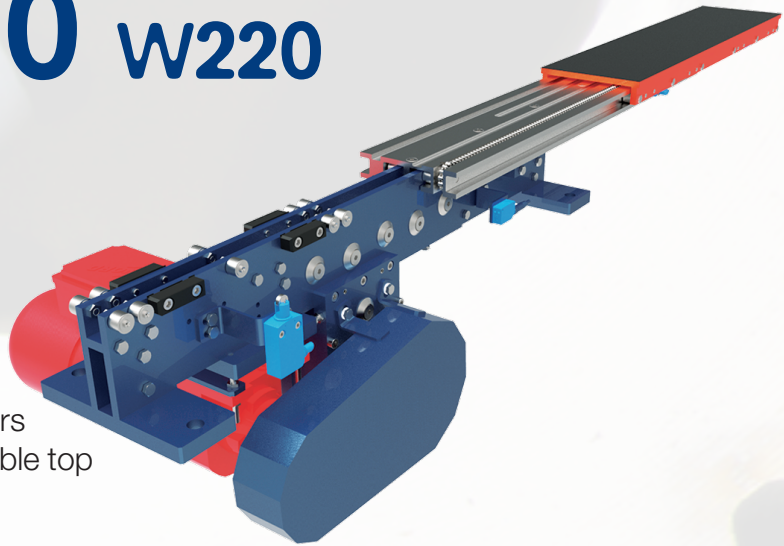

# ARES 40 W220

It's the most important fork within the ARES series. It's a peculiar device whose main purpose is to handle unusual, bulky and heavy loads.

The motion system is a chains/gears compound, thus it can stand remarkable top speed and acceleration.



SINGLE DEPTH

DOUBLE DEPTH

TRIPLE DEPTH

PRODUCT CODE	Q LOAD (KG)	L FIXED BODY LENGTH (MM)	LS UPPER SLIDE LENGTH (MM)	S1 STROKE (MM)	MAX BENDING UNDER LOAD (MM)
AR40W-065	100	650	650	750	6
AR40W-070		700	700	800	7
AR40W-080		800	800	900	8
AR40W-100		1000	1000	1100	13
AR40W-120		1200	1200	1300	18
AR40W-125		1250	1250	1350	20
AR40W-145	80	1450	1450	1550	25

The wider top plate (provided with grip pad) allows carrying the load safely and firmly. It's particularly indicated for high-performances mini-load plants with high-paced work cycles. The width of the upper plate can change according to the customer's needs.

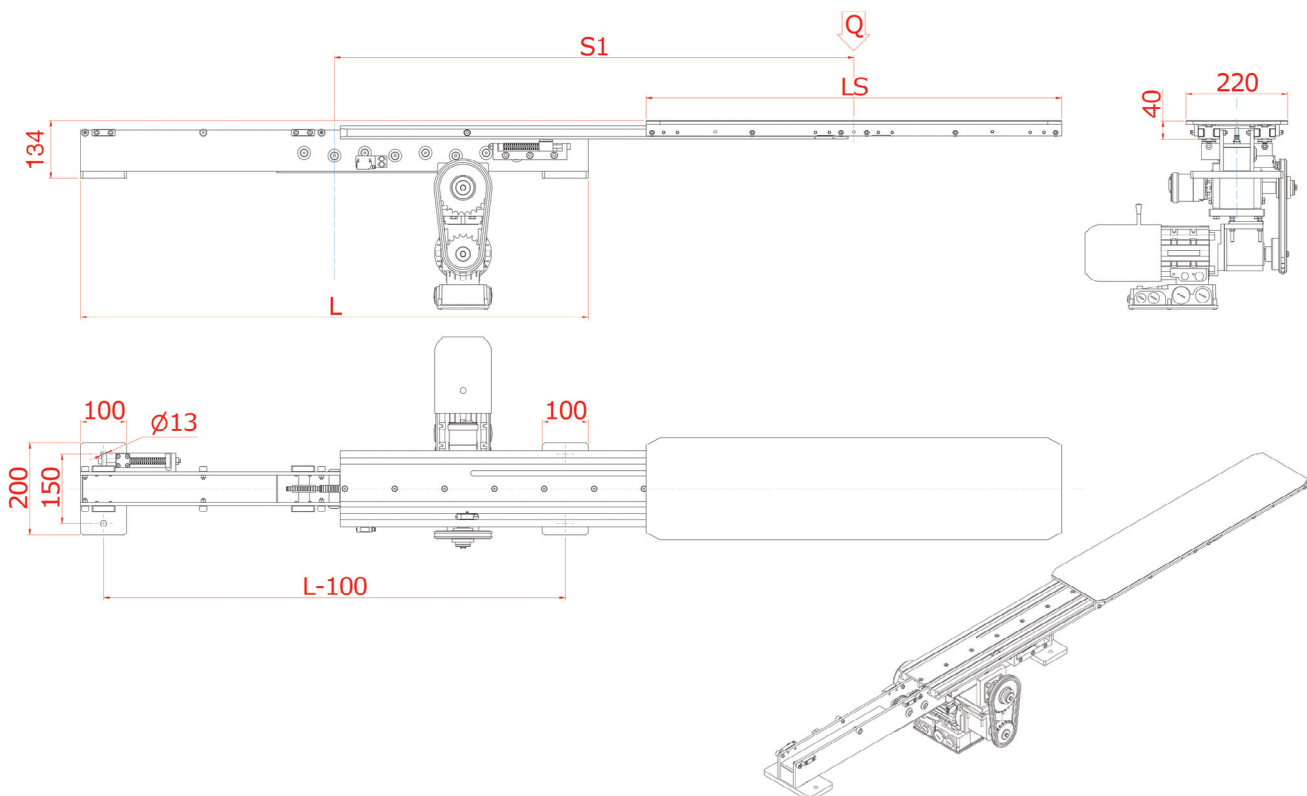

COMBINED PRODUCTS

SPECIAL PRODUCTS