

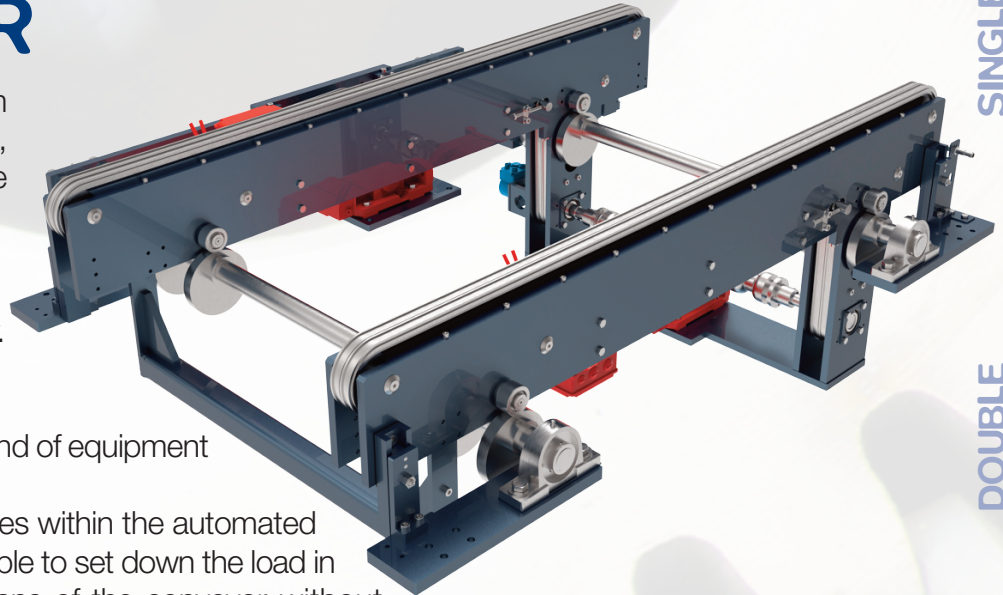

# APOLLO TRANSFER

This is a compound system (telescopic forks + conveyor), designed to implement the handling functionality. With forks in home position, the conveyor lifts, allowing to handle the pallet separately.



SINGLE  
DEPTH

DOUBLE  
DEPTH

The benefits of this peculiar kind of equipment are:

- 1) Reduction of the cycle times within the automated warehouse, since it's possible to set down the load in the unloading bay by means of the conveyor without using the forks;
- 2) Improving the positioning of the load on the shelf, since it's possible to align the load to the forks in masked time, in order to set it down always in the same position.

Q	LOAD (KG)	LS	LIFTING STROKE (MM)	T	LIFTING TIME (SEC)
500	500	100	100	8	8
1000	1000	60	60	5	5

TRIPLE  
DEPTH

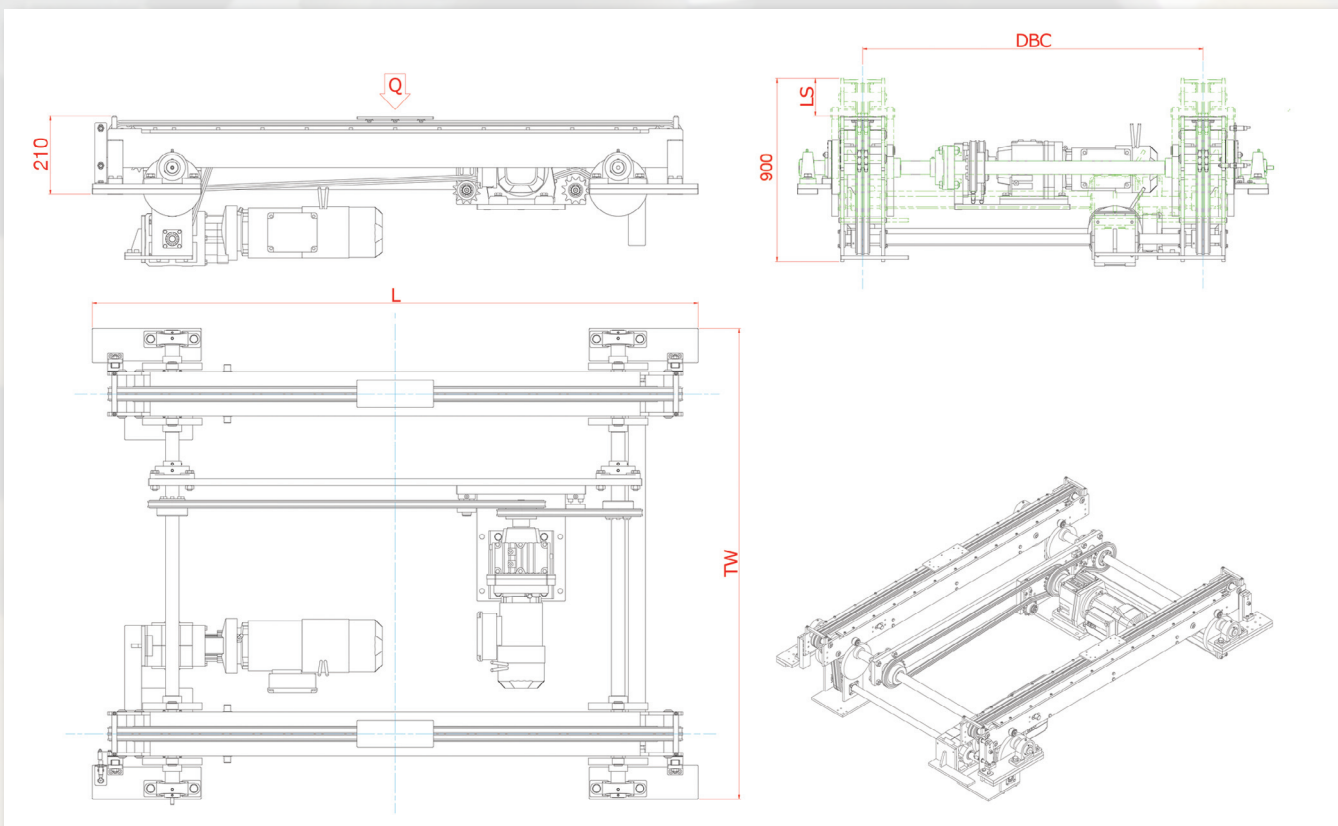

COMBINED  
PRODUCTS

SPECIAL  
PRODUCTS